

T8 TUBE – TYPE A&B

IMPORTANT SAFEGUARDS

READ ALL WARNINGS AND INSTRUCTIONS PRIOR TO INSTALLING THE T8 RETROFIT LAMPS TO ENSURE SAFETY AND PROPER OPERATION

WARNINGS - Risk of fire or electric shock. LED Retrofit Kit installation requires knowledge of luminaires electrical systems. If not qualified, do not attempt installation. Contact a qualified electrician in accordance with the National Electrical Code and relevant local code.

WARNINGS - Risk of fire or electric shock. Install this kit only in the luminaires that have the construction features and dimensions shown in the photographs and/ or drawings and where the input rating of the retrofit kit does not exceed the input rating of the luminaire.

WARNINGS - To prevent wiring damage or abrasion, do not expose wiring to edges of sheet metal or other sharp objects. Do not make or alter any open holes in an enclosure of wiring or electrical components during kit installation.

This item is rated at 120-277V/ Installer must determine whether line voltage 120-277V is available at the luminaire before installation.

CONSULT A QUALIFIED ELECTRICIAN TO ENSURE CORRECT BRANCH CIRCUIT CONDUCTOR.

NOT FOR USE WITH DIMMERS.

SUITABLE FOR DAMP LOCATIONS.

THIS DEVICE IS NOT INTENDED FOR USE WITH EMERGENCY EXIT FIXTURES OR BATTERY BACKUPS.

! WARNING DISCONNECT POWER BEFORE INSTALLING OR SERVICING.

DIRECT REPLACEMENT:

1. Switch off power to luminaire.
2. Remove diffuser (if provided).
3. Remove existing fluorescent lamp(s) from luminaire.
- Note:** Verify that the fluorescent tube type is listed on the LED lamp label.
4. Install LED lamp (one for each fluorescent lamp removed, ensure pins are firmly seated in lamp holders).
5. Switch on power to luminaire and reattach diffuser (if provided).

BALLAST BYPASS DOUBLE-ENDED POWER:

Suitable for use with both shunted and non-shunted lamp holders.

THE BELOW BALLAST WIRING REPRESENTS TYPICAL CONFIGURATION.

The actual ballast wiring varies according to ballast model. It is not needed to change socket (if in good condition) to operate double ended lamps, regardless the type of sockets. Please make sure one side of fixture is connected to Live (L) and the other side to Neutral (N).

RETROFIT LUMINAIRE FOR BYPASS • 1 LAMP

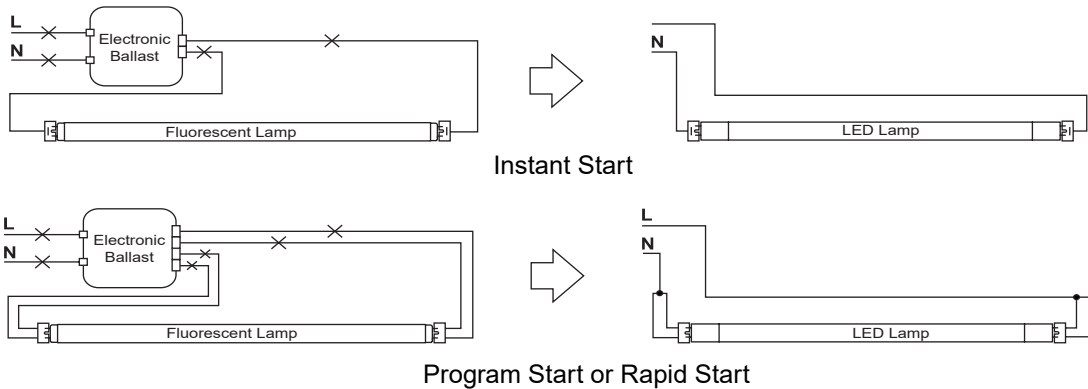

RETROFIT LUMINAIRE FOR BYPASS • 2 LAMPS

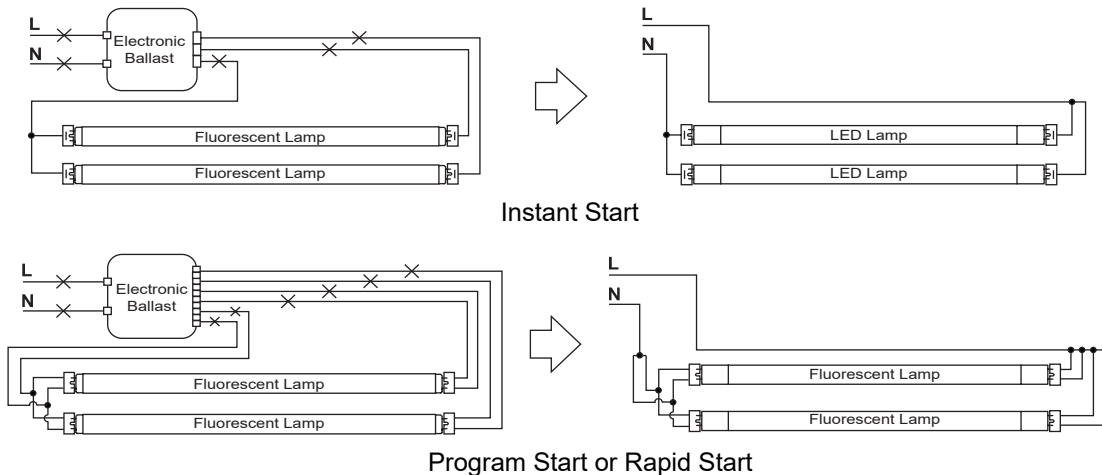

T8 TUBE – TYPE A&B

RETROFIT LUMINAIRE FOR BYPASS • 3 LAMPS

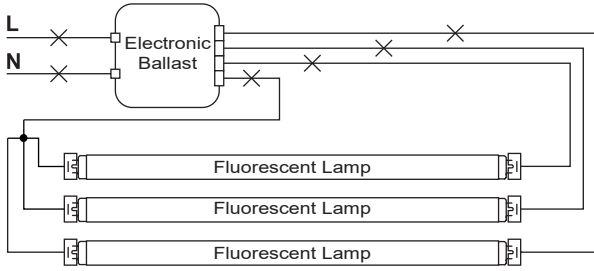

Instant Start

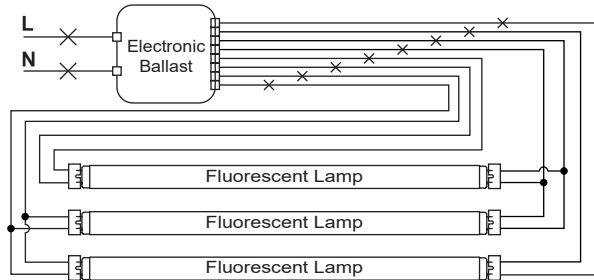
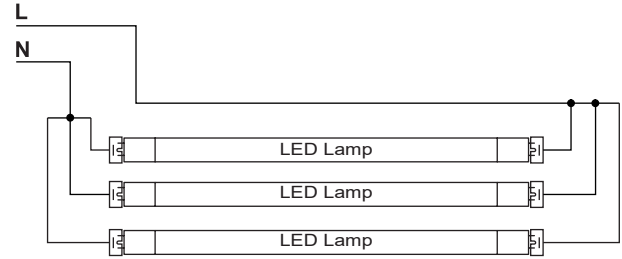

Program Start or Rapid Start

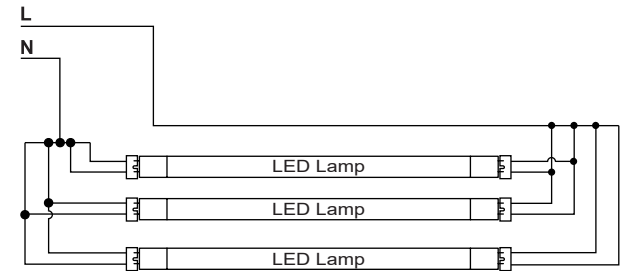

RETROFIT LUMINAIRE FOR BYPASS • 4 LAMPS

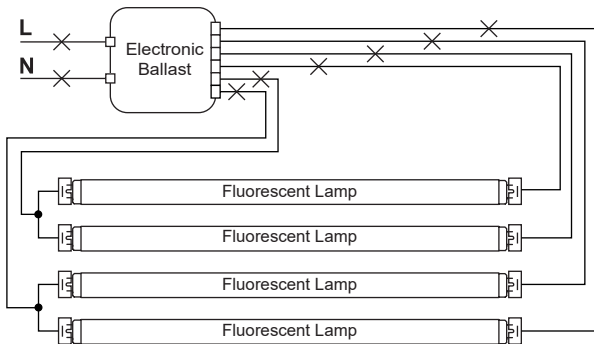

Instant Start

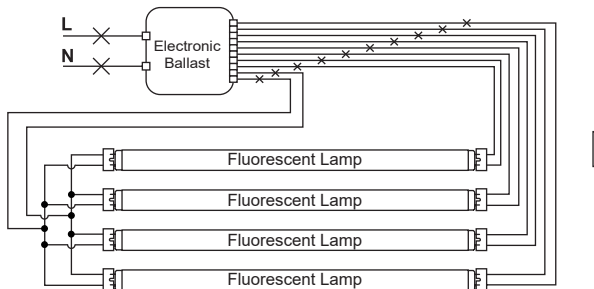
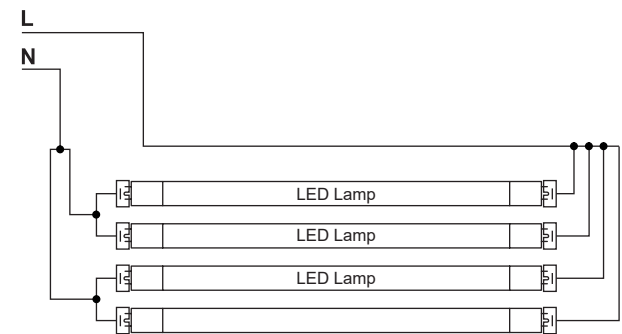

Program Start or Rapid Start

